

Rings to support the cut-outs
3 TO 4 mm thick

Weld Ring 2 centrally on Cut-out 1

C Pemberton-Pigott

Weld Ring 1 centrally under the
top deck hole

Top Deck Outside
dimensions

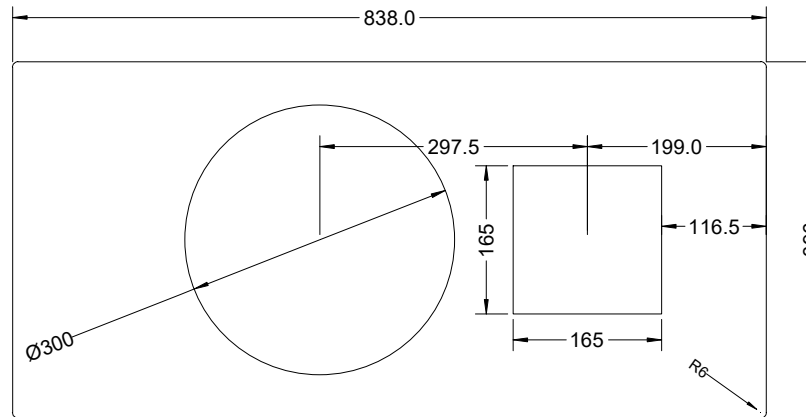

Flat Sheet Metal Top v1.3

This top deck has a no
lip and needs more bolts
so as not to bend

Top Deck with
40mm Lip

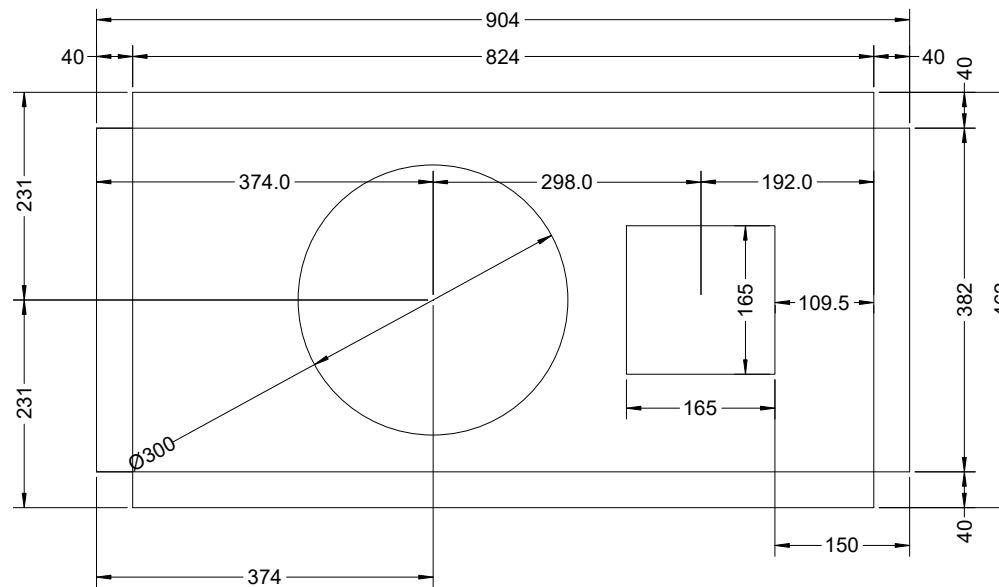

Bent Sheet Metal Top v1.3

Material: 5mm Mild steel
Bend 90 degrees
Weld the corners
Grind smooth

This top deck has a 40mm
folded lip all round.

